

505XT Digital Control

for Steam Turbines

Applications

The 505XT controller is designed to operate single valve, or single extraction/admission industrial steam turbines of all sizes and applications. This steam turbine controller includes specifically designed algorithms and logic to start, stop, control, and protect industrial steam turbines or turbo-expanders, driving generators, compressors, pumps, or industrial fans.

The 505XT control's unique PID structure makes it ideal for applications where it is required to control steam plant parameters like turbine speed, turbine load, turbine extraction header pressure, turbine inlet header pressure, exhaust header pressure, or tie-line power.

The control's special PID-to-PID logic allows stable control during normal turbine operation and bumpless control mode transfers during plant upsets, minimizing process over or undershoot conditions. The 505XT controller senses turbine speed via passive or active speed probes and controls the steam turbine through one or two (split-range) actuators connected to the turbine inlet steam valves.

When configured to control single extraction and or admission based steam turbines, Woodward's field-proven ratio-limiter function ensures that interaction between the two controlled parameters (i.e., speed & extraction or inlet header & extraction) is correctly decoupled. Simply by entering maximum levels and three points from the turbine's steam map (operating envelope), the 505 automatically calculates all the PID-to-valve ratios and all turbine operation and protection limits.

The 505XT controller also includes the following turbine protection functions to ensure that the turbine or its driven load (compressor, pump, generator) is not operated outside of its designed limits:

- 3 Critical speed avoidance bands
- Overspeed anticipation and shutdown protection
- Configurable under- or over-pressure shutdown logic
- Minimum and maximum speed and load settings
- Maximum low pressure stage overpressure limits
- Minimum high pressure stage flow limits

Ethernet and serial communications allow users to easily connect the 505XT into the plant or process control system. All controller inputs, outputs, and statuses can be monitored and all start/stop or enable/disable commands can be given through industry standard Modbus® * TCP or OPC protocols. The 505XT uses SNTP (synchronized network time protocol) over Ethernet to allow users to synchronize the 505XT's real-time clock to the plant distributed control system.

* Modbus is a trademark of Schneider Automation Inc.

Description

The 505XT control is packaged in an industrial hardened enclosure designed to be mounted within a system control panel located in a plant control room or next to the turbine. The control's front panel serves as both a programming station and operator control panel (OCP). This user-friendly front panel allows engineers to access and program the unit to the specific plant's requirements, and plant operators to easily start/stop the turbine and enable/disable any control mode. Password security is used to protect all unit program mode settings. The controller's 8-inch (20 cm) graphical display allows operators to view actual and setpoint values from the same screen, simplifying turbine operation.



- Field-configurable
- Integrated graphical operator control panel
- Automatic start routines
- Integrated first-out problem indicator
- Trip and Alarm event recorder
- Ext/Adm Decoupling
- User-friendly menu format
- Ext/Adm Map Display Screen
- Adaptive PID controllers
- Rotor stress monitoring
- Real-time clock synchronization via SNTP
- Ethernet communications
- Same form-fit-function as previous 505E versions
- Sulfur-resistant conformal coating
- Certified for Hazardous Locations

Turbine interface input and output wiring access is located on the controller's lower back panel. Un-pluggable terminal blocks allow for easy system installation, troubleshooting, and replacement. Optionally, users can increase the number of input and output signals to/from the 505 by connecting pre-programmed LINKnet HT™ distributed I/O nodes to the 505XT's CAN communication ports. These special distributed I/O modules are designed to allow for the flexibility of mounting by the turbine or by the controller, depending on customer's preference. The following additional I/O signals can be connected to the 505XT via CAN communications:

- 16 4–20 mA input channels and 4 4–20 mA output channels (via 2 LINKnet HT AIO modules)
- 8 RTD signals (via 1 LINKnet HT RTD module)
- 16 Discrete inputs (via 1 LINKnet HT DI module)
- 16 Relay output drivers (via 1 LINKnet HT DO module)

Designed for steam turbine control, the 505XT control includes five PID controllers (Speed, Ext/Adm, Cascade, Aux-1 Aux-2) multiple start-up routines (manual, semi-auto, automatic, remote control), and multiple protection functions (overspeed, critical speed range, max power, etc.) which can be configured by a user depending on the specific turbine application's requirements. Users can configure the 505XT's different PID controllers, start routines, and protection levels themselves without the need for a special control engineer.

Once configured, the 505XT performs a configuration check routine to ensure that the programmer did not make any basic configuration mistakes.

Optionally, users can utilize Woodward's RemoteView software program with the 505XT to function as a remote operator control panel and/or engineering station. Once loaded onto a remote computer or touch panel, this software program allows the computer or touch panel to perform all of the 505XT front panel display functions (monitor, operate, tune, and configure). Password-based login level security allows users to manage which functions they want the remote panel user to have. Refer to product specification 03424 for more information on RemoteView's capabilities.

The 505XT also includes a suite of service tools to allow users to perform the following functions:

- Download configuration settings files to the 505XT
- Upload configuration settings files from the 505XT to save on another device
- Upload Alarm and Shutdown event log files
- Upload datalog trend information from the 505XT to view and save on another device
- Download different language files into the 505XT
- View real-time or saved trend files

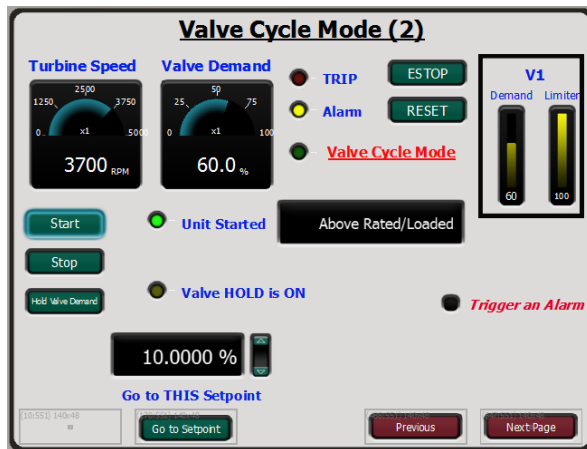

Figure 1. Example RemoteView Screens

Cost-Effective Design

The 505XT control is designed to function as the turbine control, system sequencer, operator control panel, and first-out indicator. This encompassing design minimizes external system devices as well as system installation, wiring, and troubleshooting.

This field-configurable controller allows major functional changes to be made on-site, often by knowledgeable plant personnel, and minor functional changes to be on-line as process changes require. The 505XT control's first-out-indicator logic indicates internal as well as external system related alarm and shutdown conditions, greatly simplifying and reducing system troubleshooting.

Communications

The 505XT controls can communicate directly with plant Distributed Control Systems and/or CRT-based operator control panels, through four Ethernet ports using Modbus TCP or OPC communication protocols, or via one serial Modbus port. The single serial port supports RS-232 or RS-485 communications using ASCII or RTU Modbus protocols.

Communications between the 505XT and a plant DCS can also be performed through hard-wired connections.

Control

The following PIDs are available to perform as process controllers or limiters:

- Speed/Load PID (with multiple dynamics & Adaptive PID)
- Extraction/Admission Pressure PID
- Auxiliary PID 1 (limiter or control)
- Auxiliary PID 2 (limiter or control)
- Cascade PID (Header Pressure or Tie-Line Control)

System Protection

- Integral Overspeed Protection Logic & Test Capability
- First-out Indication (10 individual shutdown inputs)
- Stuck in critical speed band logic
- Bumpless transfer between control modes if a transducer failure is detected
- Local/Remote Control priority and selection
- Fail-safe Shutdown Logic
- Mode login level password security

Control Specifications

INPUTS

- Power: LV models = 18–32 Vdc
HV models = 88–264 Vac & 90–150 Vdc
- Speed: 2 Passive MPUs or 2 Active Proximity probes (0.5—32 000 Hz)
- Discrete Inputs: 20 Configurable Contact Inputs
- Analog Inputs: 8 Configurable 4–20 mA Inputs (optionally 16 additional inputs via LINKnet HT modules)

OUTPUTS

- Valve/Actuator Drivers:
2 Actuator Outputs, 4–20 mA or 20–200 mA
- Discrete Outputs:
8 configurable Relay Outputs (2 relays rated for 24 Vdc @ 5 A, 6 relays rated for 24 Vdc @ 2 A) (optionally 16 additional outputs via LINKnet HT module)
- Analog Outputs:
6 Programmable 4–20 mA Current Outputs

COMMUNICATIONS

- Ethernet: 4 ports (Modbus TCP or OPC protocols)
- Serial: 1 Modbus port (ASCII or RTU) Comm Ports (RS-232 or RS-485 compatible)
- CAN: 4 ports (LINKnet HT comm protocol)

Functionality

The 505XT's control capabilities are:

- Speed/Frequency Control
- Extraction and/or Admission Header Pressure Control
- Turbine or Generator Load Control or Limiting
- Turbine Inlet Header Pressure Control or Limiting
- Turbine Exhaust Header Pressure Control or Limiting
- Plant Import/Export Power Control or Limiting
- Isochronous Load Sharing between units (with DSLC™-II control)
- Control of any process directly related to unit load

Operating Conditions

- –25 to +65 °C ambient air temperature range
- Humidity: Lloyd's ENV2 test #1
- Dry Heat: Lloyd's ENV3
- Salt Fog: US MIL-STD-810 method 509.2 procedure 1
- Shock: meets US MIL-STD-810C, method 516.2-1, procedure 1B
- Vibration: Lloyd's ENV2 test #1

Pollution Resistance

- Particulate Pollution Resistance: IEC 664-1 Pollution Degree 2 (normally only non-conductive pollution occurs)
- IEC 60068-2-60:1995 Part 2.60 Methods 1 and 4 (Flowing Mixed Gas Corrosion Test)
- Gaseous Pollution Resistance: Module conformal coating withstands NO₂, CO₂, SO₂, and H₂S gases
- Will withstand levels typical of telecommunications and computer installations as defined by Battelle Labs Class III (between IEC60721-3-3 classification 3C1 and 3C2, light industrial to urban industrial, heavy traffic)

Regulatory Compliance—PENDING

European Compliance for CE Marking

These listings are limited to only those units bearing the CE Marking.

- EMC Directive: 89/336/EEC COUNCIL DIRECTIVE
- ATEX Directive: 94/9/EEC COUNCIL DIRECTIVE Zone 2, Category 3, Group II G EEx nA II T3 X

Features

- Critical Speed Avoidance (3 speed bands)
- Auto Start Sequence (hot & cold starts)
- Multiple Ratio/Limiter Decoupling Mode
- Valve Limiter(s)
- Security (program is password protected)
- Adaptive Speed/Load PID Dynamics
- First-Out Indication (shutdowns)
- Zero Speed Detection with proximity probe (< 0.5 Hz)
- Peak Speed Indication for overspeed trip
- Multi-lingual Display (English & Chinese)
- Remote analog setpoints for Speed/Load, Aux, and Cascade
- High Speed Digital Communications to Woodward actuators and power management products

Control Accessories

RemoteView—Once installed on a computer or touch panel, the RemoteView software program can be used as an engineering workstation and/or remote operator control panel. As an operator control panel, this software program can be used to monitor all system parameters, start and stop the turbine, and enable/disable all modes of operation.

Control Assistant—The Control Assistant software program functions as an engineering workstation and/or service tool that can be used with the 505 control to view real-time trends, view saved trend files, or compare differences in configuration files. As an engineering workstation, this software program can be used to upload and download settings and log files to and from the 505 controller (details in product spec 03424).

AppManager—Tool for setting the IP addresses of the Ethernet ports, setting SNTP functionality, Program upload/download capability, retrieving datalog files, Start/Stop the Display program (to change languages).

Other International Compliance

- GOST R: Certified for use in explosive atmospheres within the Russian Federation per GOST R certificate POCC US. ГБ04.В01002 as 2ExnAIIТ3Х
- C-Tick (ACA/RSM): Declared to Australian Radiocommunications Act of 1992 and the New Zealand Radiocommunications Act of 1989

North American Compliance

- UL Listed for Class I, Division 2, Groups A, B, C, and D, T3A at +60 °C Ambient (rear enclosure provided) and T3B at +65 °C Ambient (rear enclosure omitted) for use in Canada and the United States. UL File E156028.

Marine Compliance

- Lloyd’s Register (LR): Environmental Category ENV3 , Lloyd’s Register Type Approval Test Specification Number 1, July, 2013.

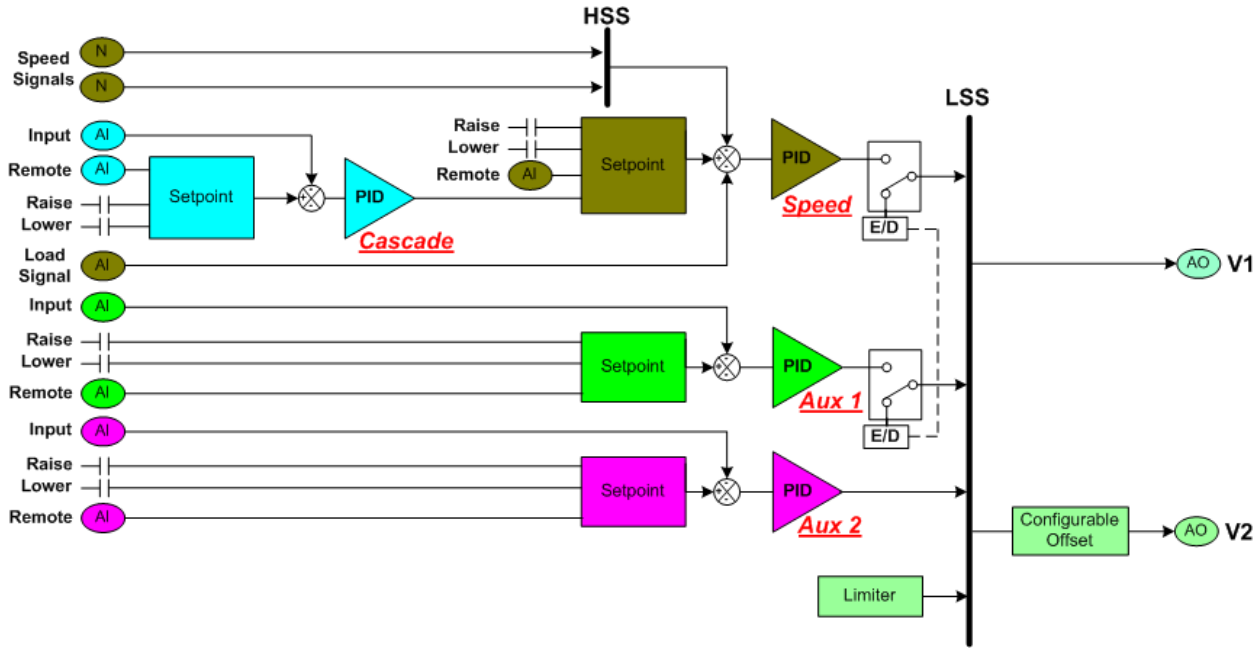

Figure 2. Basic Single Valve or Split Range Functional Control Diagram

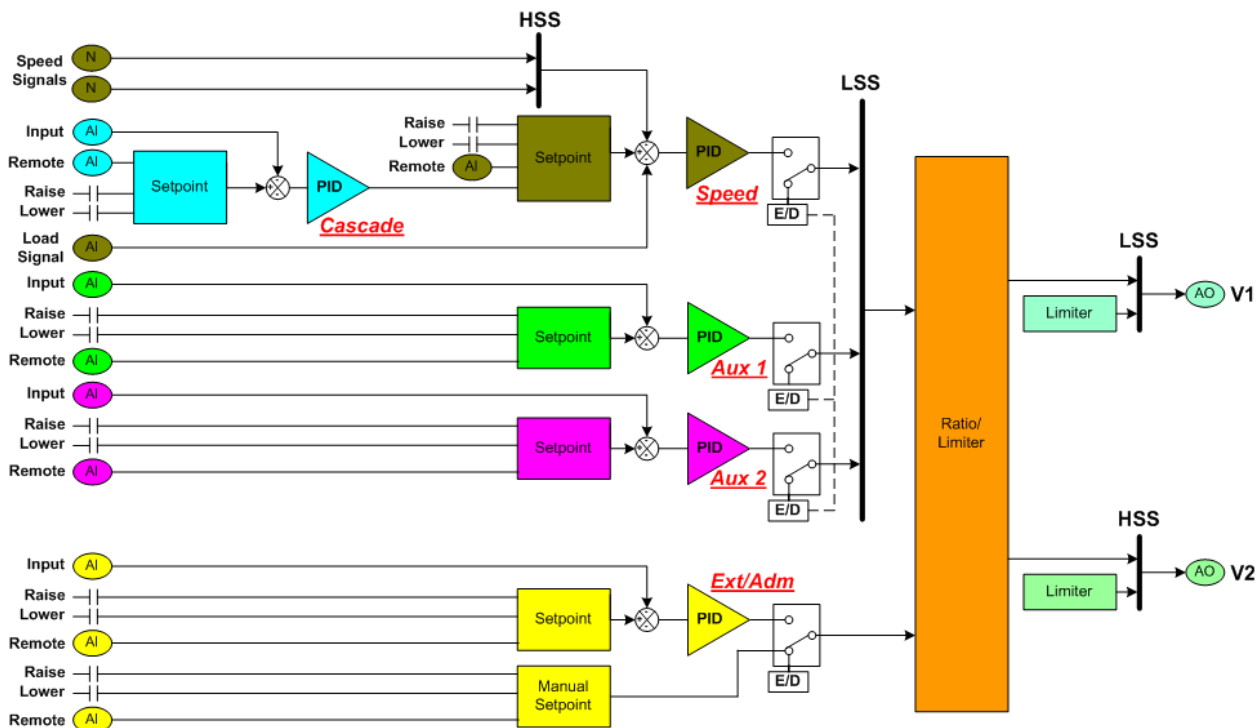

Figure 3. Basic Ext/Adm Functional Control Diagram

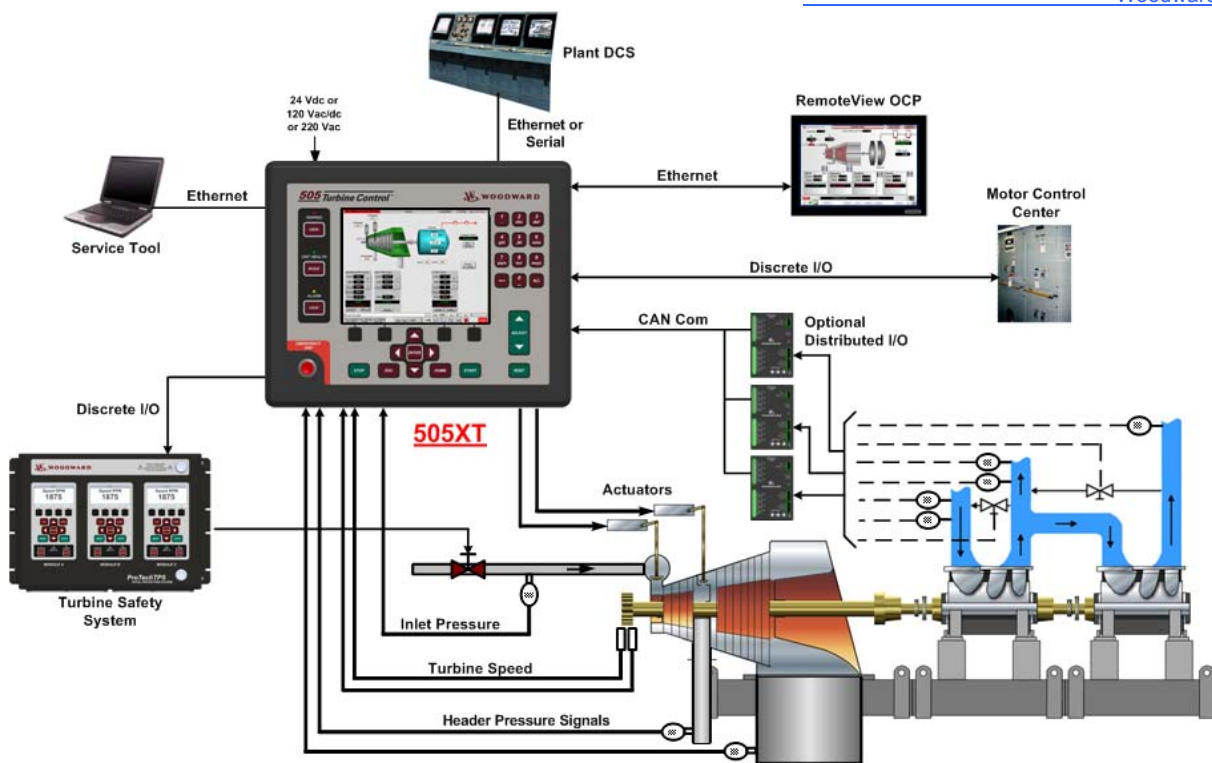

Figure 4. Typical 505XT Application

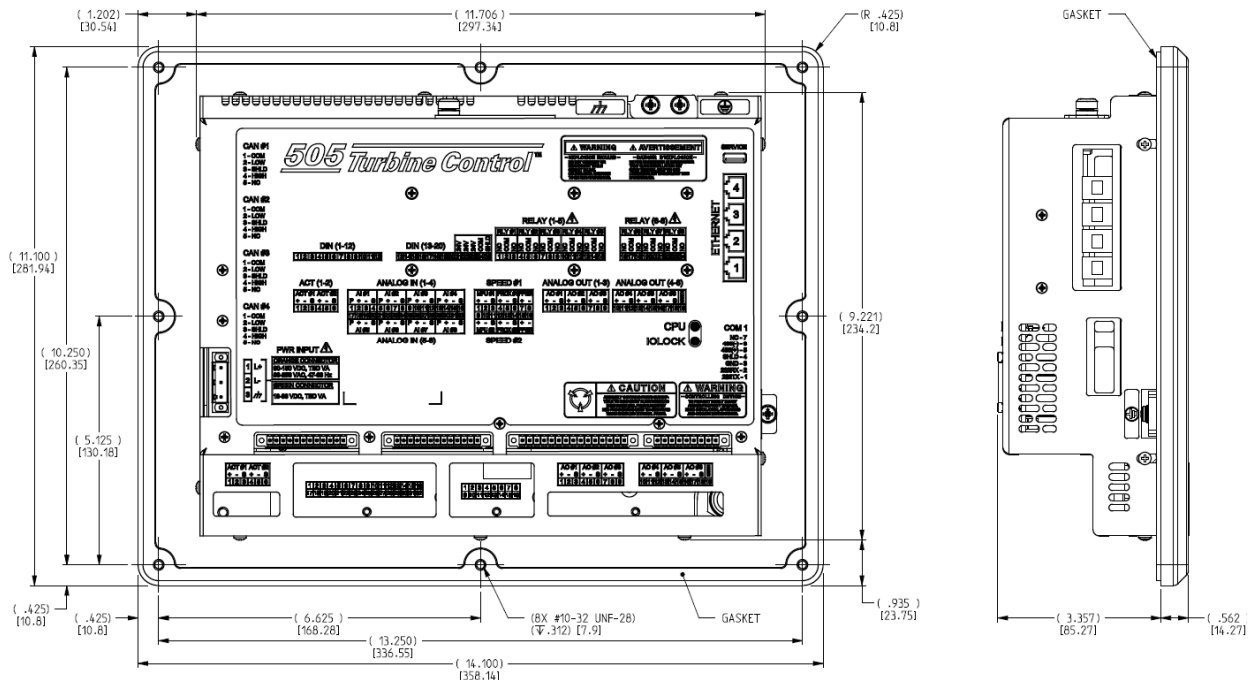

Figure 5. 505XT Dimensions
(Do not use for construction)



PO Box 1519, Fort Collins CO 80522-1519, USA
 1000 East Drake Road, Fort Collins CO 80525, USA
 Phone +1 (970) 482-5811 • Fax +1 (970) 498-3058
 Email and Website—www.woodward.com

Woodward has company-owned plants, subsidiaries, and branches, as well as authorized distributors and other authorized service and sales facilities throughout the world. Complete address / phone / fax / email information for all locations is available on our website.

This document is distributed for informational purposes only. It is not to be construed as creating or becoming part of any Woodward contractual or warranty obligation unless expressly stated in a written sales contract.

Copyright © Woodward 2014, All Rights Reserved



For more information contact: